

Oil Fired Water Heater

Technical Notes, Installation, Operation and Maintenance Instructions

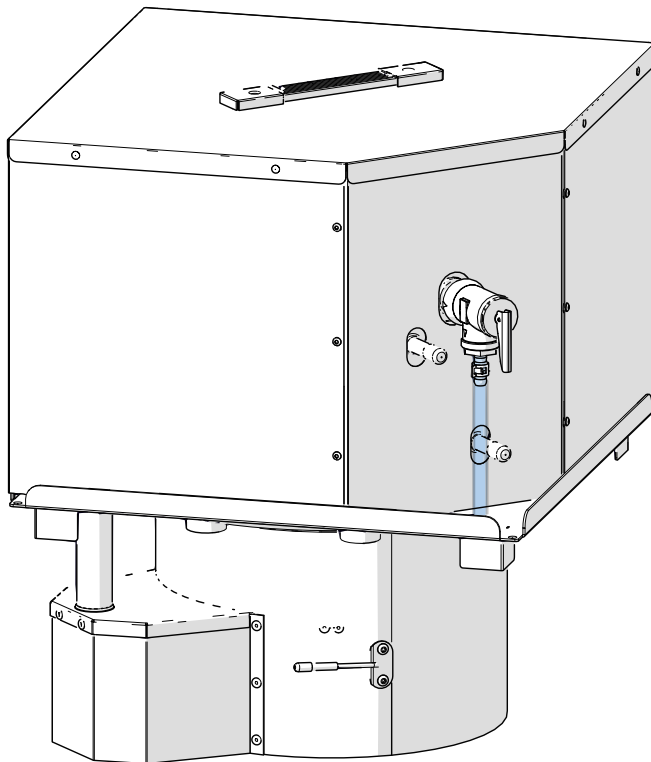

Plateau version 1.00

Production Type

Diesel & Electric: DC12V/AC220V

Diesel & Electric: DC12V/AC110V

Diesel: DC12V

Foreword

Thank you for using this water heater

This manual describes the technical description, installation, operation and maintenance of the water heater. In order to ensure the correct use of the water heater, please read this manual carefully before installation and use. After reading, please keep it properly for future reference.

Note:

- The contents of this manual may change without further notice, but it can be guaranteed that this manual is consistent with the purchased product.
- We will try our best to express clearly what users want to know through the manual. If you have any questions or find something inappropriate, please contact the company directly.
- When the user unpacks for the first time, please check the main unit and accessories against the packing list, if any problem is found, please contact the seller immediately.
- If there is any failure during use, please contact the marketing department of our company or the customer service station authorized by our company, we will serve you wholeheartedly.



It must be installed and used in accordance with the requirements of this manual to ensure long-term stable and reliable operation of the product!

Table of Contents

Symbols used	2
Intended use	2
Safety instructions	2
Technical data	4

Installation instructions

Test water tank	6
Host fixation	7
Installation diagram of water heater	10
Install the oil transfer pipe	11
Install the oil pump	12
Connect water heater and oil pump	12
Install the fuel filter	13
Install oil suction pipe	13
Install the water connection	14
Electrical connection	18

Operating instructions

Safety instructions	19
Fault description	21
Matters needing attention	23
Accessories	24
Touch switch manual	26

Symbols used



The unit may only be installed and repaired by an expert.



Symbol indicates possible hazards.



Note containing information and tips.

Intended use

The oil fired water heater (hereinafter referred to as the water heater) is a kind of equipment specially designed to provide hot water for use in bathing for station wagons, yachts and outdoor shelters. If there are other uses, users need to judge whether they meet the safety standards of the corresponding industry.

Safety instructions

Safe working environment

- The water heater can only be operated with the standard control panel and accessories.
- The water heater must be installed and used horizontally.
- It is prohibited to use the water heater in a closed or poorly ventilated space. If the water heater is in a closed or poorly ventilated space, it is necessary to turn off the water heater at this time, otherwise there is a danger of exhaust gas poisoning.
- Do not park the vehicle in a place with weeds or waste paper, because the exhaust pipe of the vehicle and the exhaust pipe of the water heater may ignite weeds or waste paper.
- Thermal sensitive objects (such as spray cans) or flammable materials and liquids cannot be stored in the installation compartment of the water heater, because in some cases, the area may be affected by high temperature.
- The vicinity of the exhaust pipe shall be kept away from inflammables, and it is not allowed to block the outlet of the exhaust pipe.

-
- Keep the exhaust pipe and combustion air inlet free from pollution (snow, ice, leaves, etc.) at all times.

Safe operation

- Make sure there is good ventilation under the vehicle. There may be some smoke or smell when the heating is started, because of dust or pollutants. Especially when the equipment is not used for a long time.
- The integrity and tight fit of the water heater must be checked regularly. Especially after long-distance travel, the fixation and installation of the device should be checked.
- When cleaning the vehicle, do not spray water directly into the combustion chamber under the vehicle.
- Before plugging and unplugging the terminal, please ensure that all power circuits are disconnected (i.e. AC220V or AC110V and DC12V).
- The continuous leakage of the valve of the safety valve indicates that there is a problem with the water heater.
- In case of overtemperature and overpressure of the water heater, water will be discharged from the safety valve, and its drain pipe shall be led to the outside of the vehicle.
- The safety valve shall be operated regularly to ensure its safe operation (manually open the handle of the safety valve and observe the drainage condition; when the handle is released, the safety valve shall be drained without water).
- Any drain pipe connected to the safety valve shall be installed in a continuous and downward direction and in a frost free environment.
- Any work involving circuit and waterway connection must be carried out by qualified professionals.



The inlet pipe and outlet pipe shall not be hung with redundant accessories (the user shall take necessary measures to prevent them from being subjected to excessive gravity). Excessive shaking will cause water leakage at the water pipe interface.



It is not allowed to cut off the power supply forcibly. The power supply can be cut off only after the machine stops working completely.

User's responsibilities

- Before using the water heater, the user must fill the water tank of the water heater with water. Dry burning is strictly prohibited.
- The user is responsible for the correct operation and use of the equipment.
- The liquid fuel system must comply with the national technical and administrative regulations and the national legislation and regulations.
- Check the water system regularly. If the water pipe is broken, please replace it in time.
- When the water heater is not in use, please drain the water in the water heater to avoid frost. The company will not maintain or compensate for the damage caused by frost.
- The company will not be liable for any failure or abnormal operation of the water heater (including accessories) caused by any modification or use of non-original parts or non-compliance with the installation and operation instructions.

Mode selection :

There are three energy modes to choose from:

- Fuel mode

Automatically adjust the heating power of fuel.

- Mains mode (optional)

Select 1800W electric heating mode manually according to the power supply capacity of RV camp.

- Mixed mode (this mode can only be used with electric heating mode)

Fuel and electric energy are heated simultaneously.

The water temperature can be manually set from 40 °C to 60 °C. Since the temperature in the water tank is not uniform, the set temperature is the average water temperature of the water tank and does not represent the immediate outlet temperature of the water outlet.

Technical data

Rated voltage: DC12V

Maximum working current: 8-10A

Average working current: 0.3-0.5A

Fuel type: Diesel

Fuel power: 4500W

Fuel consumption: 190-460 ml / h

Water capacity: 18 L

Rated water pressure: ∇ 0.4MPa

Working environment temperature: 1°C - 40 °C

Working altitude: 0-5000m

Action water temperature of safety valve:
94 °C - 99 °C

Action water pressure of safety valve:
0.5 ± 0.05Mpa

The host weight:

Including electric heating: 13.3KG

Excluding electric heating: 12.6KG

Electric heating parameters: (optional)

Voltage: AC220V

Electric heating power: 1800W

Reserves the right to make technical changes

Installation instructions



The unit may only be installed and repaired by an expert.
Read the installation instructions carefully before working,
and then comply with them!



Disregarding installation instructions or erroneous
installation can put people in danger and cause damage to property.

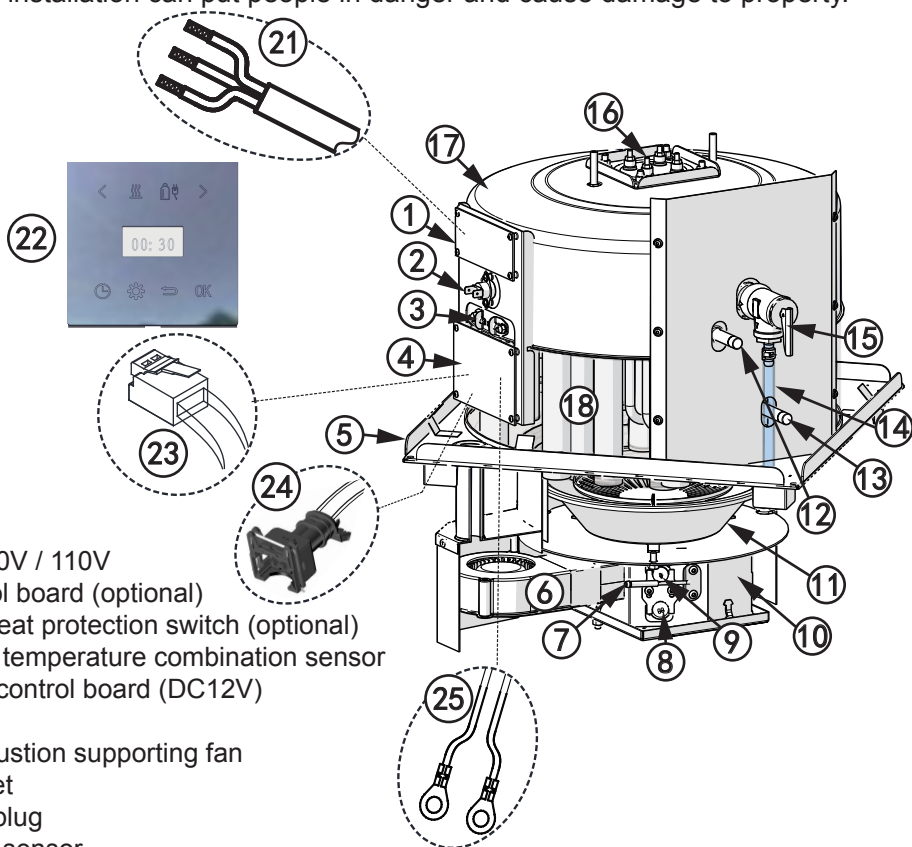

- 1 - AC220V / 110V control board (optional)
- 2 - overheat protection switch (optional)
- 3 - water temperature combination sensor
- 4 - main control board (DC12V)
- 5 - base
- 6 - combustion supporting fan
- 7 - oil inlet
- 8 - glow plug
- 9 - flame sensor
- 10 - combustion chamber
- 11 - windproof hood
- 12 - water outlet pipe (outer diameter 10mm)
- 13 - water inlet pipe (outer diameter 10mm)
- 14 - drain pipe
- 15 - safety valve
- 16 - electric heating device (optional)
- 17 - water tank
- 18 - exhaust pipe (8 groups)

- 21 - AC220V / 110V power line (optional)
- 22 - touch switch
- 23 - touch switch lead
- 24 - oil pump lead
- 25 - DC12v power line

Test water tank

i Before installation, the inside of the water tank needs to be flushed and tested for tightness

Flushing and sealing test can be carried out according to the method shown in Fig. 1 (Reference method):

- Seal and fix the water inlet pipe and the faucet (ensure that there is no leakage at the connection).
- The hand valve of the outlet pipe is in the open state (open direction).
- Open the faucet to flush the water tank until the water is clear from the hand valve outlet.
- Close the hand valve (off direction).
- When the safety valve is dripping, close the faucet (use the collective water supply system pressure test).
- After the above, observe whether there is leakage at the welding of the water tank (except frost and dew). If there is leakage at the welding, please contact the dealer in time. Note that the quick plug pipe fittings should be kept horizontal with each other, otherwise there is a risk of leakage.
- After there is no leakage, drain the water in the water tank.

Water discharge steps: slowly open the hand valve until the water pressure is completely removed, and then pull out the quick connect pipe ② until no water is discharged from the water inlet pipe.

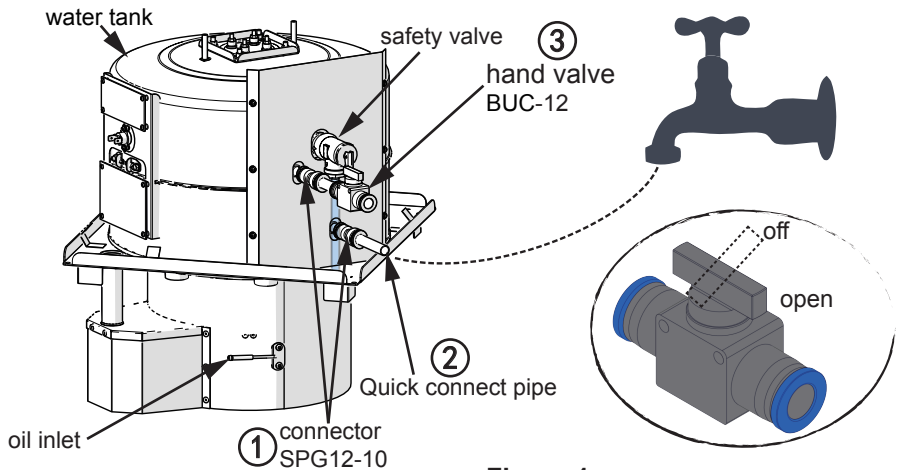

Figure 1

i For the parts marked with serial numbers "①、②、③" in Fig. 1, please contact the supplier or our company if necessary.



Avoid water splashing on the circuit board and electrical components during the test. Ignoring the installation instructions or installing incorrectly will put people at risk and cause property damage.

Host fixation

Cut the base hole

The installation position of the water heater shall be the bearing floor, and the base hole shall be square. The specific cutting holes are as shown in Figure 2:

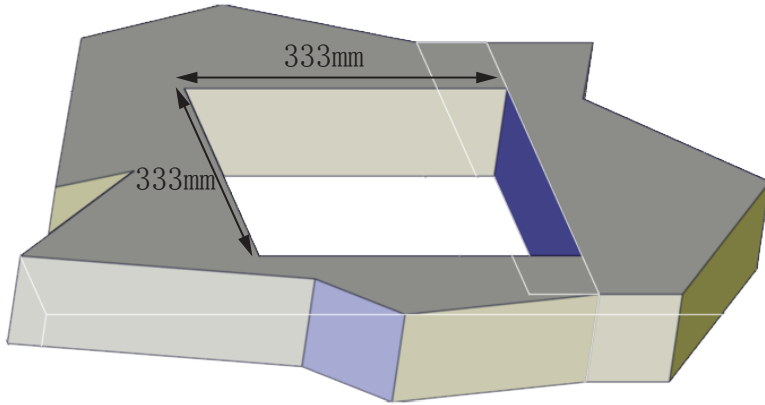

Figure 2

Install the protection plate

First, apply sealant on the inner surface of the guard plate as shown in Fig. 3, and press and fix it on the surface of the base hole according to the direction shown in the figure.

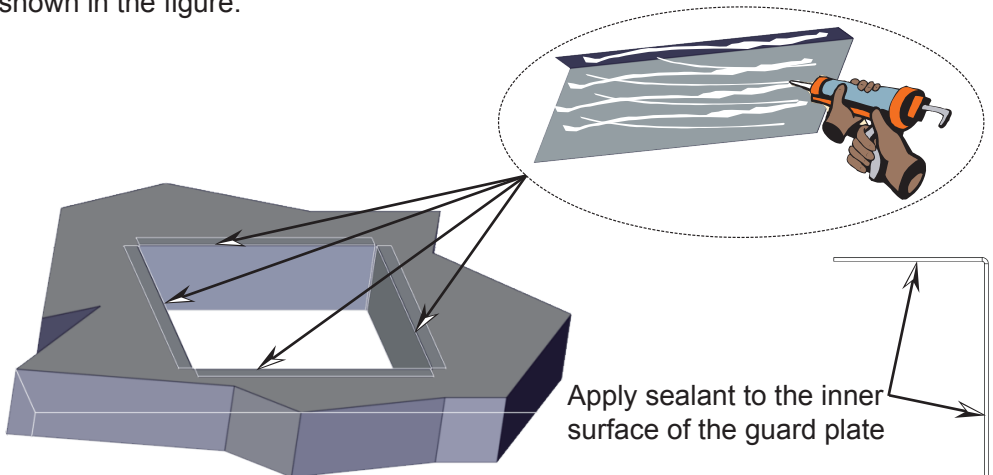
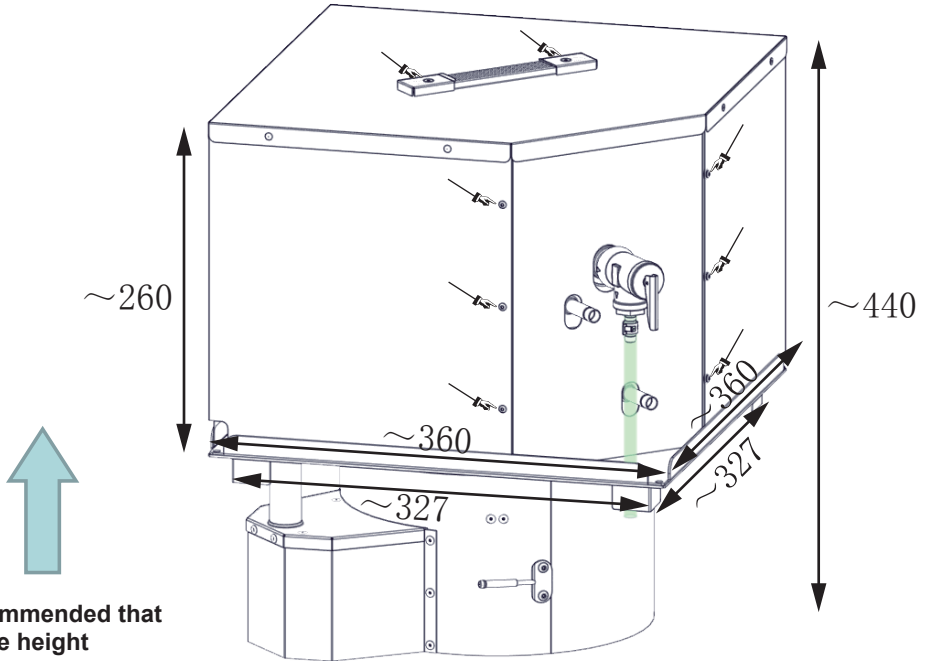

Figure 3

Remove the housing

Remove the screws pointed in Figure 4 and remove the housing.



It is recommended that the space height (in the direction of the arrow) should not be less than 600mm.

Figure 4 Dimensions in mm. Not shown to scale.



The installation space is based on the product size to meet the convenience of disassembly and assembly!

Fixed water heater

Drill self tapping screws according to the holes at the four corners of the base (the fixing position of the water heater is according to the customer's requirements).

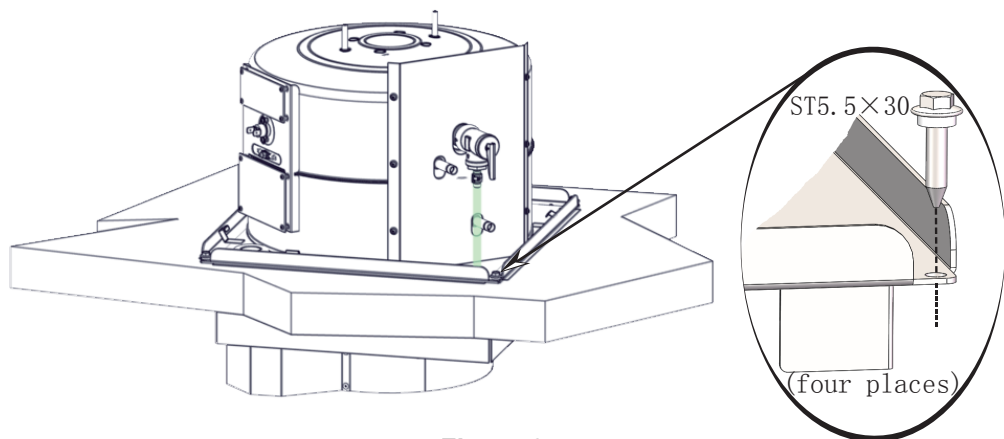

Figure 6



The water heater must be fixed to the mounting surface with screws to prevent danger during driving.

Reinstall the housing

After the housing is installed in place, screw the screws pointed in Fig. 7.



After the cable is pulled out of the cable hole, it is fixed on the construction surface to prevent the loose connection of electrical parts caused by movement!

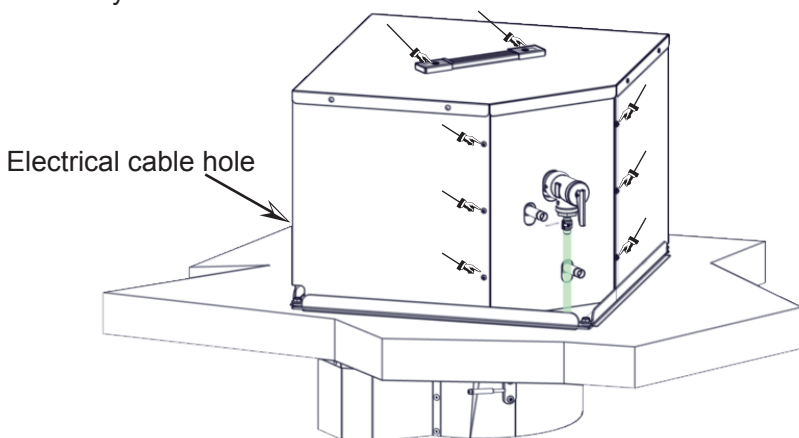

Figure 7

Installation diagram of water heater

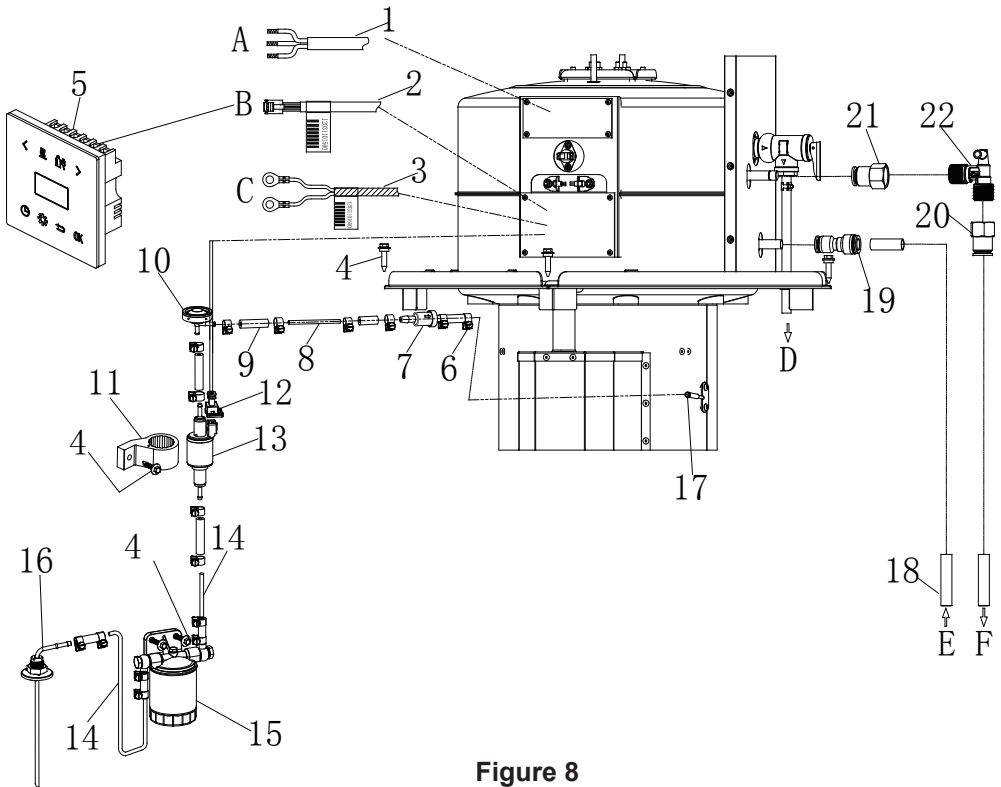

Figure 8

- 1_ AC220V / 110V power cord 2_ Touch switch lead 3_ DC12V power line
 4_ Self tapping screw ST5.5 × 30 5_ Touch switch 6_ Clip (φ 9-11)
 7_ Check valve 8_ Nylon oil pipe (transparent, main engine to oil pump)
 9_ Oil pipe joint 10_ Buffer 11_ Oil pump fixing ferrule 12_ Oil pump lead
 13_ Oil pump 14_ Nylon oil pipe (blue, oil tank to oil pump)
 15_ Fuel filter (diesel only) 16_ Oil suction pipe 17_ Oil inlet pipe (main engine end)
 18_ Quick intubation 19_ Straight reducer quick connector (spg12-10)
 20_ Internal thread straight joint (spcf12-04)
 21_ Internal thread straight joint (spcf10-04) 22_ Exhaust valve

- A_ Connected to AC220V power supply B_ Connected to touch switch
 C_ Connected to DC12V battery D_ Row to the outside of the vehicle
 E_ Connected to system water tank F_ Connected to water equipment



For the parts marked with serial numbers "18、19、20、21、22" in Fig. 8, please contact the supplier or our company if necessary.

The fuel system means that the fuel is extracted from the vehicle fuel tank or supplied from the special fuel tank and delivered through the special oil pump (provided by the manufacturer). It is not allowed to extract fuel from the return system of the vehicle engine or downstream of the vehicle internal transfer pump. Only use the fuel hoses and lines in the scope of delivery for installation.

i The fuel oil shall comply with GB19147-2013 vehicle diesel standard

! In winter, the fuel shall be of the grade meeting the low temperature requirements, and biofuel is not allowed.

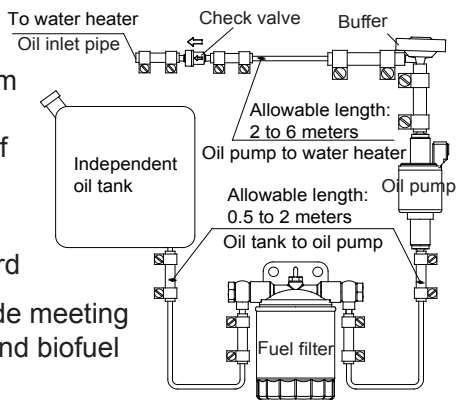

Figure 9 Schematic diagram of fuel pipe system

Install the oil transfer pipe

Only flexible nylon pipes with good light resistance and thermal stability provided with the water heater can be used as fuel pipes. Allowable fuel pipeline length: the maximum length of the fuel pipeline from the oil tank to the oil pump side is 2 meters, and the maximum length of the fuel pipeline from the oil pump to the machine is 6 meters.

Safety regulations for fuel pipeline

The fuel hose must be cut to the required length with a hose cutter or sharp knife. The cut area shall not be compressed and free of burrs. The fuel lines must be firmly connected to prevent damage and noise caused by vibration (it is recommended that the distance between the connection points is about 50cm). The fuel piping must be protected from mechanical damage. The laid fuel pipeline shall not adversely affect the turning of the vehicle and the stable operation of the engine. Protect fuel carrying parts from high temperatures (use suitable glass fiber lined aluminum thermal protection hoses). Do not lay or fix the fuel line near the water heater or the exhaust pipe of the vehicle engine.

! If the lines cross, please keep enough distance from the hot parts. The installation position of oil pipe shall be able to prevent the impact of flying stones, and shall be away from the heating parts of the vehicle. If necessary, heat radiation protection plate can be used.

Install the oil pump

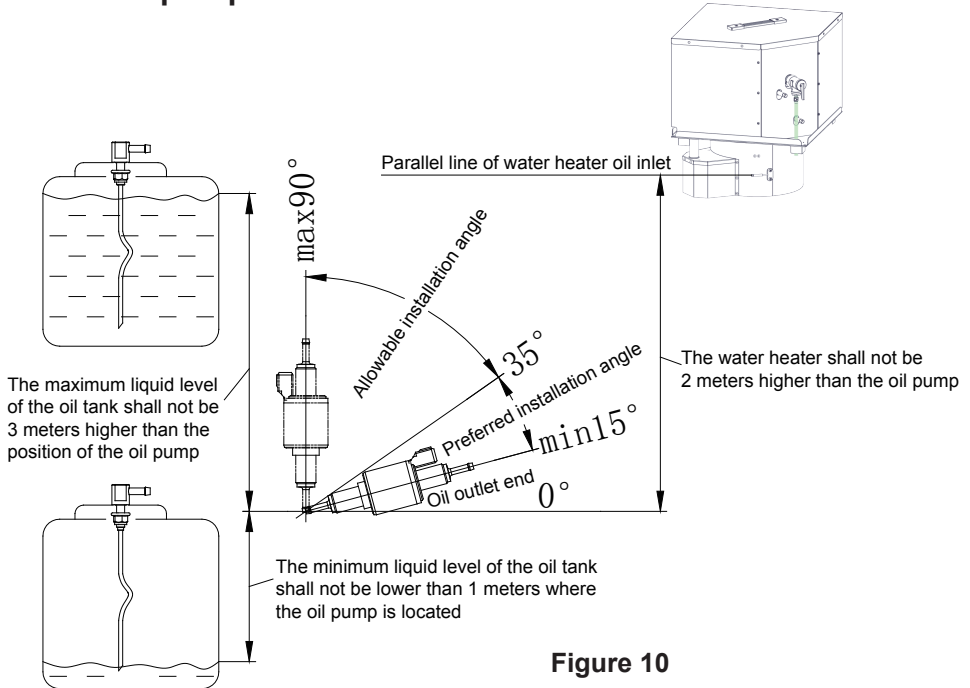

The oil pump shall be fixed with oil pump fixing ferrule (rubber). The oil outlet of the oil pump shall be inclined upward, and its installation angle shall be selected within the range of 15° ~ 35° (as shown in FIG. 10). When conditions permit, the oil pipe from the oil pump to the water heater shall gradually rise. The oil pump shall be protected from high temperature (the maximum operating temperature is 40 °C), so do not install the oil circuit system near the exhaust pipe.

The height difference between the fuel level and the oil pump and the height difference between the oil pump and the parallel line of the oil inlet of the machine will generate pressure (or suction) in the oil circuit, so these dimensions should meet the requirements of "figure 10".

Connect water heater and oil pump

The oil pipe from the oil pump to the water heater shall be upward as far as possible. Mark the hole required for passing through the fuel pipeline and the connecting cable of the oil pump at a suitable position on the vehicle floor.



Before drilling, be sure to check hidden cables, fuel pipes, etc!

In order to prevent the cable between the oil pipe and the oil pump from being cut, a protective sleeve can be sleeved. The oil pipes shall be bound at suitable places for fixation, and the binding spacing shall not be greater than 50cm.

For the connection between the oil pipe and the oil pump, the water heater and the oil tank (oil nozzle), the oil pipe joint provided by the machine shall be used, and the oil pipe clamp shall be used to clamp tightly, so as to prevent bubbles at the connection (FIG. 11).

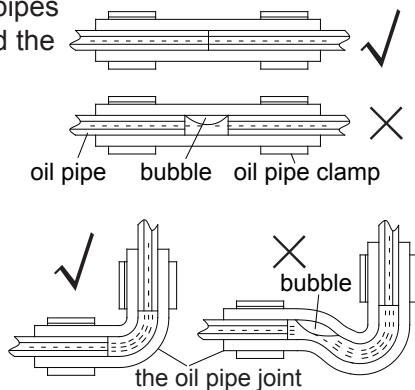
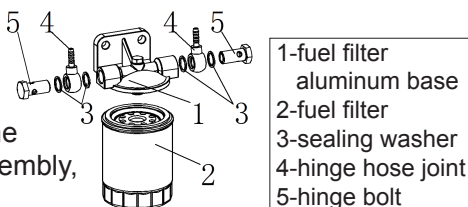

Figure 11

Install the fuel filter

Install the fuel filter in front of the oil inlet of the oil pump. During installation, pay attention to the fact that the fuel filter must be vertically upward (ensure that impurities deposit downward). When installing for the first time, unscrew the aluminum seat, fill the fuel filter with fuel, and then use it after assembly, which can shorten the pumping time.



i The replacement cycle of fuel filter is two years, and the fuel pipe connector and fuel pipe clamp must be replaced at the same time.

Install oil suction pipe

When sucking fuel from the fuel tank of the vehicle, it must be installed from the upper surface of the fuel tank, not from the side of the fuel tank.

1. Installation of oil suction pipe: attention shall be paid to the installation hole (size: $\phi 25 \pm 0.2$) the edge shall be flat without burrs, and the sealing gasket under the oil pipe seat shall be installed in place. The distance between the lower end of the oil suction pipe and the bottom of the oil tank should be 30-40mm, which can not only ensure the full absorption of fuel, but also prevent the absorption of impurities deposited at the bottom of the oil tank. (See Figure 12 for details)

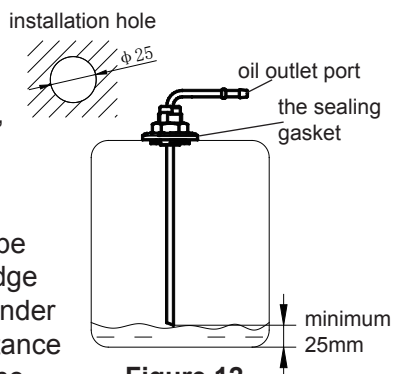

Figure 12

2. Installation of oil suction pipe: attention shall be paid to the installation hole (size: $\phi 6 \pm 0.1$) the edge shall be flat without burrs, and the O-ring under the oil pipe seat shall be installed in place. The distance between the lower end of the oil suction pipe and the bottom of the oil tank should be 30-40mm (the length of the oil pipe can be adjusted by truncation or bending, but the smoothness of the oil pipe cannot be affected). If it is too low, it is easy to suck impurities deposited at the bottom of the oil tank into the oil pipe.

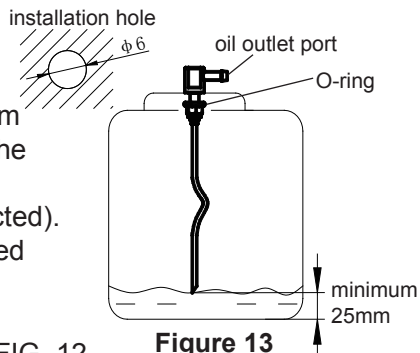

Figure 13

i The two types of oil suction pipes shown in FIG. 12 and FIG. 13 can be purchased by users according to their needs.

i Only one type of oil suction pipe is shown in the installation diagram of the water heater in Fig. 8, and the installation methods of the two types of oil suction pipes are the same.

Install the water connection

The water supply pressure of this water heater shall not be more than 0.4MPa, and the water supply pressure must also meet the rated pressure that the selected pipeline and its accessories can bear.



When there is frost, please drain the water in the water tank in advance.

Install water pipe joint - refer to method 1

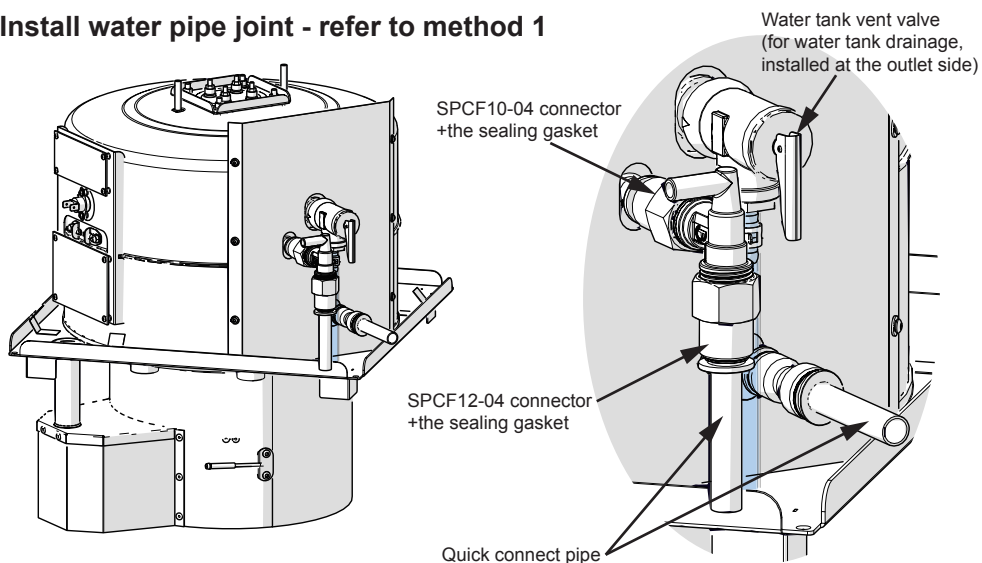

- i** - The inner diameter of quick connect pipe (temperature resistant plastic pipe) shall be at least 10mm to facilitate the flow of water;
 - For quick plug series connectors, please refer to the "quick connector" list;
 - Quick connector series, quick connect pipe and exhaust valve need to be purchased additionally.
- i** It is recommended to use PEX water pipe for quick connect pipe, which has excellent high and low temperature resistance and low temperature toughness. The recommended outer diameter of the pipe is 16 (0, + 0.3) mm, which can meet the normal use of the water heater.

Quick connect layout requirements

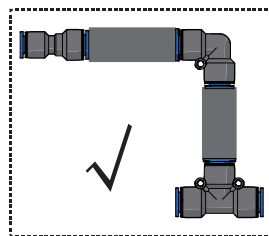
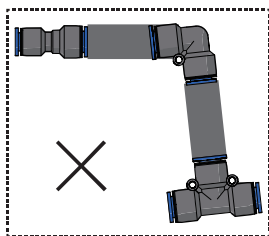
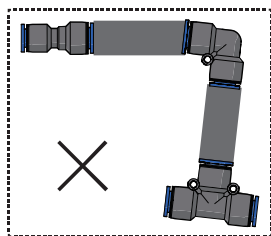

i Quick plug is one of the connection methods, and other connection methods shall comply with the "safety instructions"

- When quick connect accessories are required to be matched, they need to be inserted in place.
- !**
- It is required that the pipeline should be arranged horizontally and vertically.
 - It is not allowed that the water pipe is too long or too short, which will lead to water leakage at the joint.
 - It is required that the pipes shall be arranged with the least turns and the shortest distance.
 - The snap ring can be selected to prevent the tube from loosening. See "Figure 14" for details.

! It is required that the cutting surface of the quick connect pipe is flush and free of burrs.

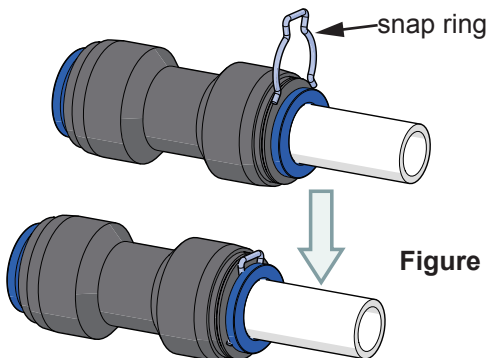
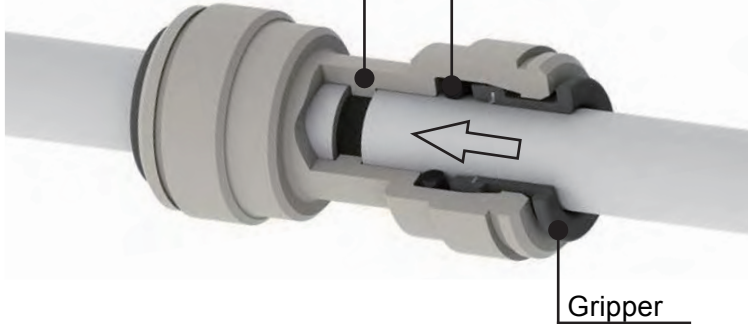

Figure 14

Quick connect layout requirements

Push the tube in the direction of the arrow until it stops

Ring seal
(provide leak proof seal)



Push the tube inside the connector

- Push the tube into the inside of the connector in the direction of the arrow until it stops.



Remove the tube

- First, push the gripper inward



Check that the tube is pushed into place

- Then pull out the tube



- Pull the tube to check that it is fully seated

Depressurize the system before disassembly, and push the gripper vertically toward the connector. After the holder is held in this position, the tube can be pulled out.

When connecting, just push the pipe in place by hand, and the gripper will fasten the pipe without deforming the pipe and restricting the flow in the pipe.

Install water pipe joint - refer to method 2

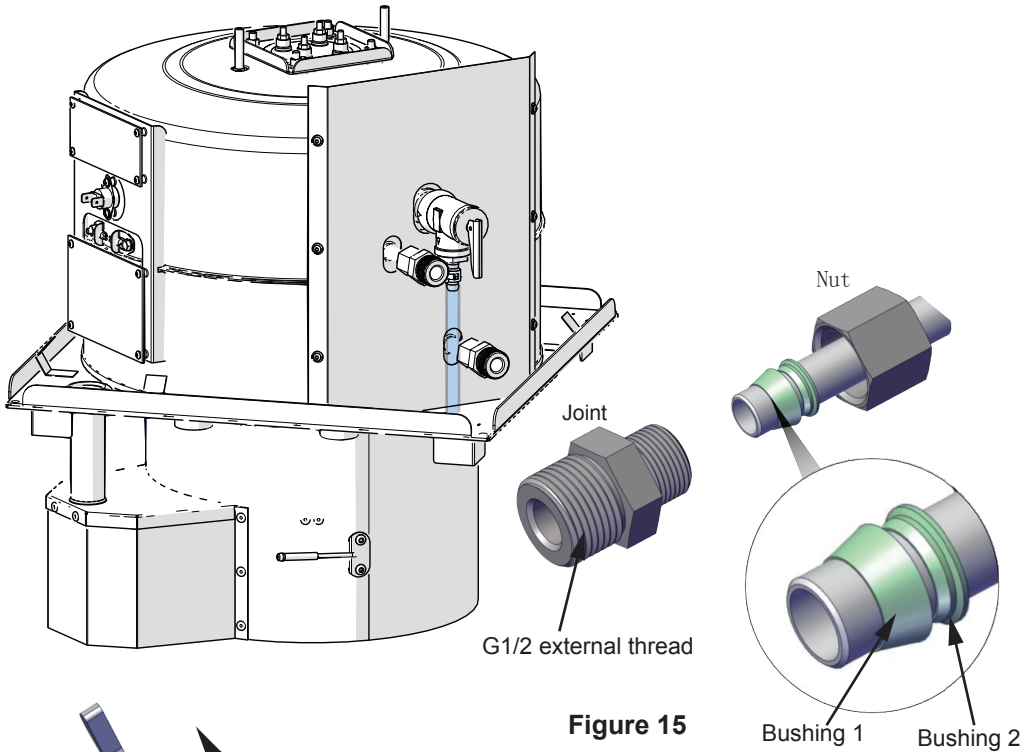

Figure 15

Installation steps are as follows:

(inlet and outlet pipes are installed in the same way)

- First pass the nut through the inlet and outlet pipes.
- Then bushing 1 and bushing 2 pass through the water inlet and outlet pipes according to the orientation of "Fig. 15".
- Finally, use two wrenches to tighten the nut and joint with the opposite force as shown in Figure 16.

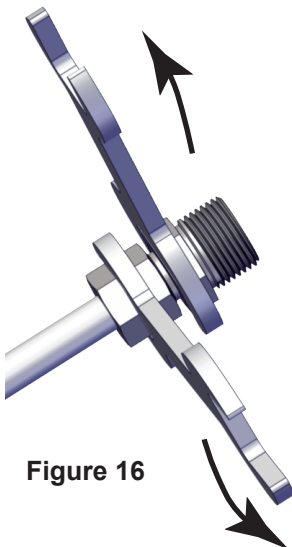

Figure 16

i If the water heater is found to have water leakage at the joint during use, it can be tightened slowly by referring to "Figure 16" until there is no water leakage.

i Ferrule joint is one of the connection methods, and other connection methods must comply with the "safety instructions"

Electrical connection

Avoid damaging the laid wires. If there are sharp edges at the place of laying, such as wire holes in metal panels, please use wire sleeves or edge protection accessories. Connector cable shall not be attached to the surface of exhaust pipe or hot air duct. The electrical connection socket is located on the control board. We will assemble it for you before leaving the factory. Do not disassemble it !

The electrical wiring diagram is as follows:

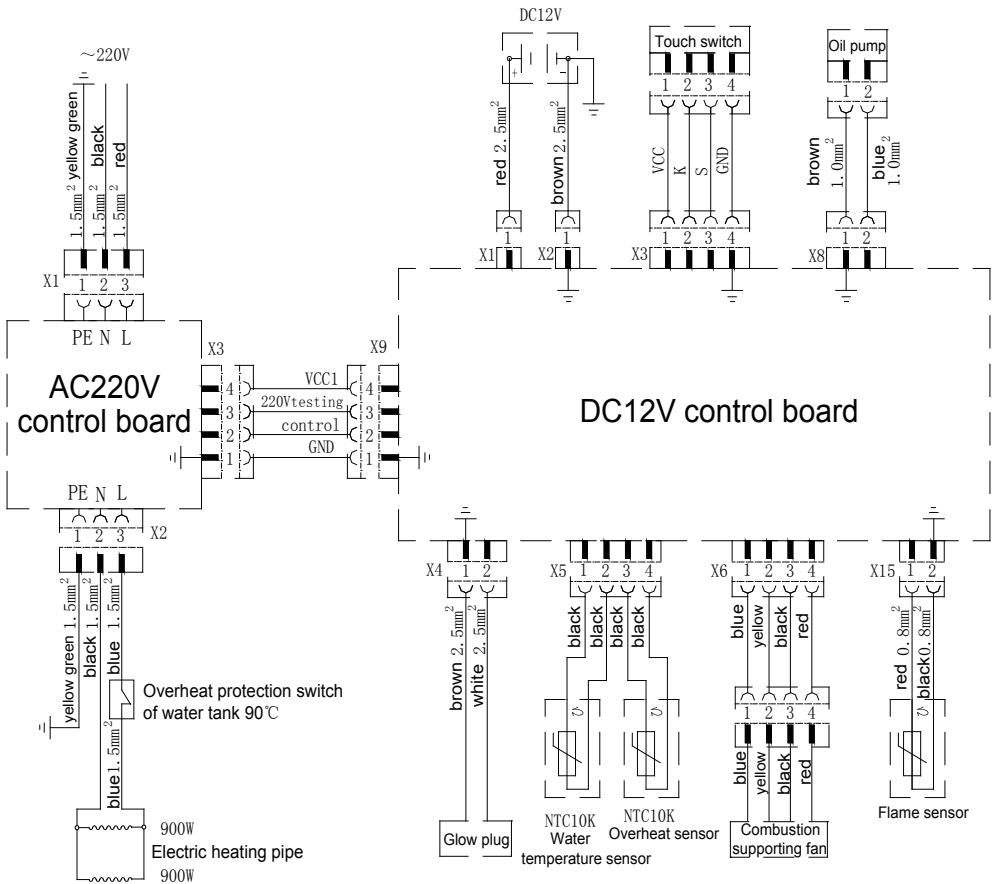

Note: the cross-sectional area of unmarked conductor is 0.3 mm²

DC12V Power Requirements

The electrical circuit, switch and control equipment of the water heater shall not be installed at a position that will adversely affect its operation. This water heater has the function of reverse polarity protection. If the polarity of the controller is not connected correctly, the heater will not start. The length and cross-sectional area of the power line shall ensure normal operation under the voltage of 12V, and the allowable voltage fluctuation range shall not be greater than 0.5V. It is recommended to configure the power cord according to the parameters in the table. The positive wire of the power supply (red) is connected to the positive pole of the automobile battery;

The negative wire of the power supply (brown) is connected to the negative pole of the car battery.

Total length of cable	Sectional area
<8m	2.5mm ²
8~12m	4mm ²
12~16m	6mm ²

Electric connection of oil pump

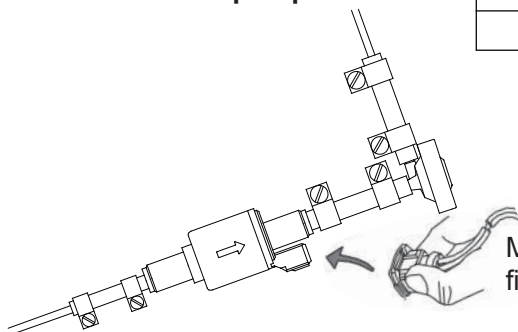

Make sure that the plug is firmly connected in place

AC220/110V Overheat protection (optional)

The electric heating has an overheating protection switch. If the water temperature exceeds $90^{\circ}\text{C} \pm 3^{\circ}\text{C}$, the AC power supply will be automatically cut off. When the water temperature drops to $70^{\circ}\text{C} \pm 10^{\circ}\text{C}$, it will automatically reset.

Electrical connection of touch switch

The water heater must be operated with a special touch switch. See the relevant instructions for details.

Safety instructions

Please read the operation manual carefully before operation.

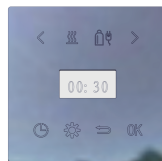

Start the water heater

- Operate with a dedicated touch switch.
- It has fuel, mains and mixed modes (both mains and mixed are optional).
- The 1800W working mode can be selected only after the RV camp has the mains energy.
- Check whether the exhaust pipe is smooth.
- The water tank is full of water.

Water tank filling

- Check whether the safety valve / drain valve is closed.
- Turn on the power supply of the water pump (main switch or pump switch).
- Turn on the hot water faucet in the kitchen or bathroom until the air is exhausted, the water tank is filled, and the water is discharged continuously.
- When the water heater is not heated, if only the cold water system is running, the water tank will be filled with water. In order to avoid frost damage, a drain valve must be installed at the inlet pipe side of the water heater to drain water (the drain valve needs to be matched by the user according to the installation method and corresponding safety criteria).
- In case of frost, if there is frozen residual water in the water tank, the water heater can be turned on first, heated for a while to thaw (no more than 10 minutes), and then filled with water.
- If the water heater is connected to the centralized water supply system (rural or urban water supply system), a pressure reducer must be used to prevent the pressure from exceeding 0.4MPa. Turn on the circulating water pump, the hot water faucet in the kitchen or bathroom in turn until the air is discharged, the water tank is filled, and the water is discharged continuously.

Turn off the water heater

- Special touch switches shall be used for operation, and forced power off is strictly prohibited.
- After the water heater is turned off, the combustion supporting fan will continue to work for several minutes according to the temperature of the furnace. In case of freezing danger, please drain the water in the water tank first.

Water heater drainage

- The RV does not use the water heater during frost and needs to drain the water in the water tank.
- Turn off the power supply of the pump unit (main power supply or pump switch).
- Turn on the hot water faucets in the kitchen and bathroom.
- Open the drain valve (equipped by the user for manual drainage).
- The water heater will directly discharge the water in the water tank to the outside through the drain valve.
- Check whether the water is discharged through the drain valve.
- This device can only be repaired and cleaned by professionals.
- When the new machine or this machine has not been used for a period of time, all hot / cold water pipes shall be thoroughly flushed before use.

Fault description

Handling of general faults:

During the use of the water heater, it may fail to start normally or turn off automatically after starting and be in a failure locked state. At this time, the water heater can be turned off for more than 5 seconds and turned on again.

The following causes may cause circuit failure of the water heater:

Connector corrosion, poor contact, wrong insertion, wire or fuse corrosion, battery pile head corrosion, etc. pay attention to inspection and maintenance during use to prevent these phenomena.

In case of the following situations, the user can handle and eliminate them by himself:

If the water heater does not start and the touch switch screen does not light up after startup, the reason is that the fuse is open or the wiring is wrong; In addition, check whether the plug on the touch switch lead is correctly connected to the host.

Fault lock state

The fault of the water heater is displayed by the fault code on the touch switch. Troubleshooting can be performed according to the methods listed in Table 1.

Troubleshooting method of lock state		
fault	fault name	troubleshooting
10	high voltage fault	check the vehicle power supply system
11	low voltage fault	check the vehicle power supply system
23	water temperature sensor open circuit	check whether the sensor is intact
24	water temperature sensor short circuit	check whether the sensor is intact
31	ignition failure	check the fuel supply system
		check whether the combustion supporting intake and exhaust ports are
		check the glow plug and flame sensor
32	combustion failure	check the fuel supply system
		check whether the combustion supporting intake and exhaust ports are
		check the flame sensor
34	open circuit of flame sensor	check the flame sensor lead
		check the flame sensor

Table 1

Troubleshooting method of lock state		
fault	fault name	troubleshooting
35	short circuit of flame sensor	check the flame sensor
43	the water temperature is too high	check whether the water tank is short of water
		check whether the water temperature sensor is intact
44	water temperature overheat switch protection	check the water temperature overheat switch
45	continuous overheating fault	check the water temperature sensor
51	communication failure	check the connecting cable
61	open circuit of oil pump	check whether the oil pump lead is damaged
		check whether the oil pump leads are connected reliably
		repair oil pump
		replace the main board
62	oil pump short circuit	check whether the oil pump lead is damaged
		check whether the oil pump leads are connected reliably
		repair oil pump
		replace the main board
63	glow plug open circuit	check the power supply voltage
		clean the carbon deposits on the glow plug
65	glow plug (no drive)	replace the motherboard
68	dry burn alarm	check whether the water tank is short of water
		check whether the water temperature sensor is intact
81	open circuit of combustion supporting fan	check combustion supporting fan
82	combustion supporting fan failed to start	check the motor lead connection
		check combustion supporting fan
83	the speed of combustion supporting fan is too low	check combustion supporting fan
120	low voltage alarm	charging is recommended
168	watchdog reset	ignore
169	abnormal power failure	ignore
220	220 / 110V (no connection)	check AC 220 / 110V power supply system
224	No start signal	replace the motherboard
238	unknown failure	ignore

Table 1 (Continued)

Matters needing attention

● First installation

- When the water heater is installed for the first time, in order to completely exhaust the air in the oil supply system, the pipeline should be completely filled with fuel. The function of separate oil supply is set. See the manual of touch switch for details.
- Wash the water tank with clean water before using the water heater for the first time.
- Start the circulating water pump.
- Turn on the hot water faucet in the kitchen and bathroom until the air is exhausted and the water tank is filled, and the water discharged from the faucet is uninterrupted.
- The water heater shall be commissioned before use. Carefully check the safety conditions of all connection positions during trial operation. If there is smoke emission, abnormal combustion noise or fuel smell, turn off the water heater to make it inoperable. It can only be used after being overhauled by professionals.
- When the water heater is used for the first time, it may emit smell for a short time. this is normal in the first few minutes of operation.

● Quarterly maintenance

Before each heating season, professional personnel must conduct an inspection and carry out the following maintenance:

- Check the air inlet and outlet for contamination and foreign matters.
- Check the circuit connector for corrosion and looseness.
- Check whether the air inlet and outlet are blocked or damaged.
- Check the fuel pipeline for leakage.

● Long term shutdown

- When the water heater is not used for a long time, it should be operated once every 4 weeks for about 25 minutes each time to prevent mechanical parts such as oil pump or combustion supporting air fan from running out of order.
- The air inlet and outlet of the water heater must be free of blockage and dirt to prevent machine failure.
- When replacing low-temperature fuel, run the water heater for at least 20min and fill the fuel system with new oil.

● other precautions

- During transportation and storage, the ambient temperature of the water heater shall not exceed the range of $-40\text{ }^{\circ}\text{C} \sim 80\text{ }^{\circ}\text{C}$ to prevent damage to electronic components.
- The installation and maintenance of the water heater can only be carried out by authorized customer service stations, and non original parts are prohibited to avoid danger.
- Turn off the water heater before refueling.
- When welding the vehicle, remove the positive power line of the water heater from the battery and ground it to prevent damage to the controller.

Accessories

(You can choose to purchase according to your needs)

Safety valve

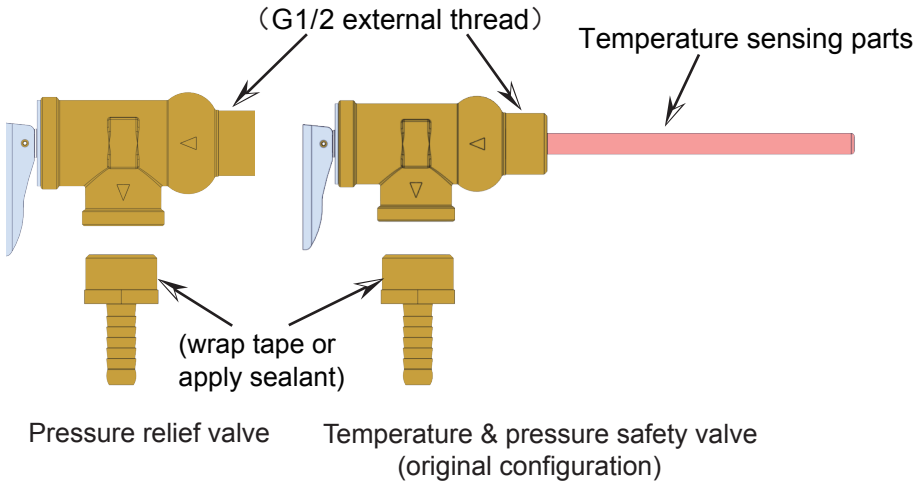

Quick connect pipe

Pressure resistance: 1.2Mpa, temperature resistance: - 40 ~ 110 °C

Sealing washer

G1 / 2 internal thread joint

PTFE TAPE

For winding thread seal

Fuel tank (10 liters)

Fuel storage container

Stainless steel ferrule

For water heater inlet and outlet pipes

Water tank vent valve

When the water tank drains, the water can be drained smoothly

Quick Connector List (additional purchase required)

Specifications	Annotation	Reference figure
SPU-12	Fit with pipe with outer diameter of 12mm	
SPU-16	Fit with pipe with outer diameter of 16mm	
SPV-12	Fit with pipe with outer diameter of 12mm	
SPV-16	Fit with pipe with outer diameter of 16mm	
SPE-12	Fit with pipe with outer diameter of 12mm	
SPE-16	Fit with pipe with outer diameter of 16mm	
SPC12-04	One side is fitted with a pipe with an outer diameter of 12mm, and the other side is G1/2 external thread	
SPC16-04	One side is fitted with a pipe with an outer diameter of 16mm, and the other side is G1/2 external thread	
SPC16-06	One side is fitted with a pipe with an outer diameter of 16mm, and the other side is G3/4 external thread	
SPCF10-04	One side is fitted with a pipe with an outer diameter of 10mm, and the other side is G1/2 internal thread	 With sealing washer
SPCF12-04	One side is fitted with a pipe with an outer diameter of 12mm, and the other side is G1/2 internal thread	
SPCF16-04	One side is fitted with a pipe with an outer diameter of 16mm, and the other side is G1/2 internal thread	
SPG12-10	One side fits with a pipe with an outer diameter of 12mm, and the other side fits with a pipe with an outer diameter of 10mm	
SPG16-10	One side fits with a pipe with an outer diameter of 16mm, and the other side fits with a pipe with an outer diameter of 10mm	
BUC-12	Fit with pipe with outer diameter of 12mm	
BUC-16	Fit with pipe with outer diameter of 16mm	
10	Matching quick connector specification: 10	 snap ring
12	Matching quick connector specification: 12	
16	Matching quick connector specification: 16	

Touch switch manual

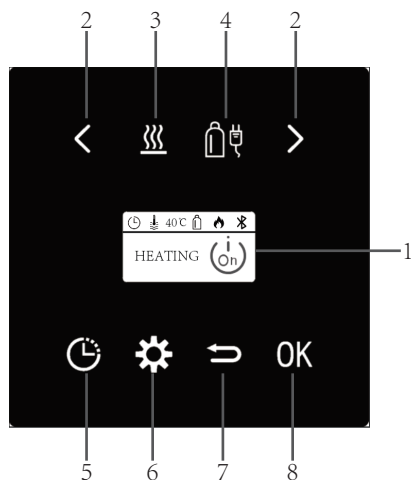

- 1 - Screen display area
- 2 - Direction key
- 3 - Heating button
- 4 - Energy button
- 5 - Timing key
- 6 - Set key
- 7 - Return button
- 8 - Confirm button

> Display and control section

Screen display area

- The touch switch controls heating, setting, timing, fault and other contents are displayed in the display area.

Direction key

- In different interfaces, touch the direction key to select, modify or save the corresponding contents in the interface.

Heating button

- Touch the heating button to enter the heating selection mode of the heating and energy menu.

Energy button

- Touch the energy button to enter the energy selection mode of the heating and energy menu.

Timing key

- Touch the timing button to set the heating timing.

Set key

- Touch the setting button to set the touch switch.

Return button

- Touch the back button to discard the current selection and return to the previous option.

Confirm button

- Touch the confirm button, select the item to confirm saving, perform the next operation, or return to the main menu.

> Switch settings

1. Power on and start

- After the touch switch is powered on, the touch switch is initialized.



- After initialization, the display area will display the heating status.



- The initialization failure display area will show no connection. (check the connecting cable between the heater and the touch switch at this time)



When the water heater is completely closed, the touch switch will wait for 30 seconds. If there is no operation command, the touch switch will automatically stand by and touch any key again to wake up.

2. Language setting

- Touch the setting button to enter the switch setting menu.



- Touch the confirm button to save the configuration and return to the previous menu.
- Touch the return button to abandon the current selection and return to the switch setting menu.

3. Bluetooth settings

- Touch the setting button to enter the switch setting menu.
- Touch the direction key to switch to Bluetooth settings.

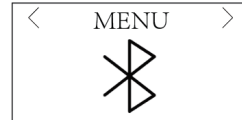

- Touch the confirm button to enter the Bluetooth settings menu.
- Touch the direction key to change the Bluetooth switch setting.

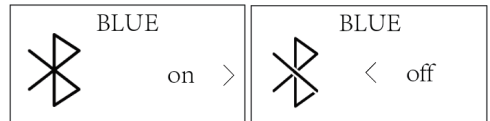

- Touch the confirm button to save the configuration and return to the previous menu.
- Touch the return button to abandon the current selection and return to the switch setting menu.

4. Sound settings

- Touch the setting key to enter the switch setting menu
- Touch the direction key to switch to the sound setting



- Touch the confirmation button to enter the sound setting menu.
- Touch the direction key to change the sound switch setting.



- Touch the confirm button to save the configuration and return to the previous menu.
- Touch the return button to abandon the current selection and return to the switch setting menu.

> Heating function setting

The heating function shall set the required heating temperature and energy.

1. Heating temperature setting

- Touch the heating button to enter the heating setting menu.

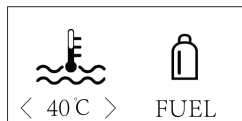

- Touch the direction key to change the required temperature, and the temperature adjustment range is 40-60 °C.

2. Heating energy setting

- Touch the energy button to switch to energy settings.
- Touch the direction key to select the required energy mode:

fuel

Mains → electric 1800W

Mixing → electric heating 1800W + fuel

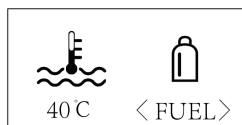

3. Start heating

- When the heating temperature and energy settings have been completed.
- Touch the confirm button to open the confirmation window.



- Touch the confirm button to start the heater and start heating.
- Touch the return button to return to the heating setting menu and reset the required temperature and energy.

4. Heating starts

- After completing the above settings, enter the heating stage.

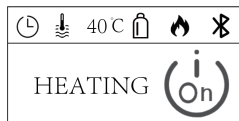

The small icons are explained from left to right as follows:

- * Timing Icon: timing mode in progress
- * Heating mode: heating water mode
- * 40 °C: required water temperature
- * Energy: fuel
- * Flame Icon: heating started successfully
- * Bluetooth Icon: in Bluetooth connection

5. Change required energy and temperature during heating

- Touch the heating button to enter the heating setting menu.

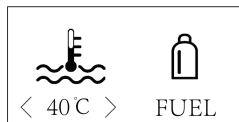

- Touch the direction key to change the required temperature, and the temperature adjustment range is 40-60 °C.
- Touch the confirm button to change the temperature setting.
- Touch the energy button to enter the energy setting menu.

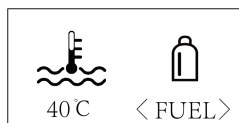

- Touch the direction key to select the required energy mode.
- Touch the Confirm button to change the energy setting.

6. Cancel heating

- Touch the return button, and a confirmation window for canceling heating will appear on the display interface.



- Touch the confirm button to exit the heating state.
- Touch the Cancel button to return to the heating interface. (Note: the water heater does not exit heating in the cancel heating confirmation window)

> Timed heating settings

Warning: exhaust gas is toxic.

The touch switch will automatically turn on the water heater when the scheduled time is reached (even if the vehicle stops or there is no one).

Exhaust gas from heating in enclosed spaces (such as garages and workshops) may be toxic.

If the vehicle is parked in an enclosed room:

- Turn off the fuel supply to the heater.
- Exit the timing state of the touch switch.



Timing settings

- Touch the timing button to enter the timing setting interface.

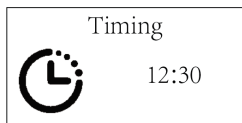

When the set duration (12 hours and 30 minutes) is reached, the user can use the hot water at the set temperature.

1. Set the timing time (set hour)

After entering the timing interface,

"12" starts flashing

- Touch the left and right direction keys to adjust "hour".
- Touch the OK key to complete the setting.
- Touch the Cancel button to exit the timing mode.

(set minutes)

After the hour setting is completed,

"30" starts flashing

- Touch the left and right direction keys to adjust "minute".
- Touch the OK key to complete the minute setting, and enter the setting temperature and energy interface at the same time.
- Touch the Cancel button to return to the hour setting.

2. Set the required temperature and time (set temperature)

- Touch the heating button to switch to the set temperature.

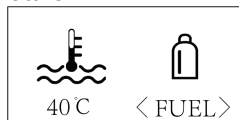

- Touch the direction key to adjust the temperature.

(set energy)

- Touch the energy button to switch to set energy.

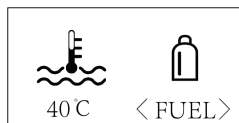

- Touch the direction key to adjust the energy.

3. Timed countdown (after setting temperature and energy)

- Touch the confirm button to enter the countdown interface.



After the user sets the "timing" function, the water heater calculates the heating duration of the set water temperature. When the timing duration is reached, the user can use the hot water at the set temperature.

> Parameter setting

1. Information query

- Touch the setting button to enter the switch setting menu.
- Touch the direction key to switch to information query.
- Touch the confirm button to enter the information query menu.



- Touch the direction key to change the information content.
- Touch the confirm button to return to the previous interface.

① Barometric pressure inquiry

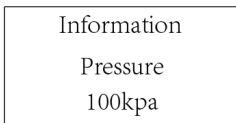

② Water heater version

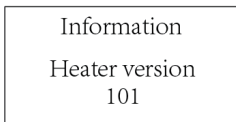

③ Touch switch version

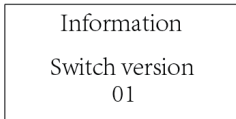

④ Working time query

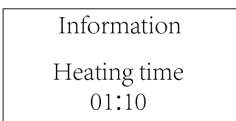

⑤ Voltage inquiry

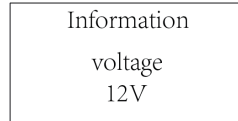

⑥ Computer monitoring mode

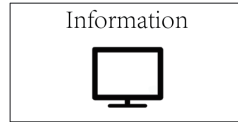

2. Fast pump oil setting

- Touch the setting button to enter the switch setting menu.
- Touch the direction key to switch to fast pump oil setting.
- Touch the confirmation button to enter the quick oil pump confirmation interface.



- Touch the confirm button to enter the default fast pumping time of 90 seconds.

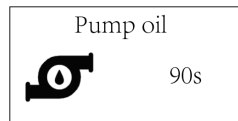

- Touch the direction key to adjust the remaining time.
- Touch the confirm button to return to 90 seconds.
- Touch the return key to exit the rapid oil pumping, and stop the rapid oil pumping when the oil pumping time reaches.

3. Restore factory settings

- Touch the setting button to enter the switch setting menu.
- Touch the direction key to switch to restore the factory settings.



- Touch the confirm button to enter the interface of restoring factory settings.



- Touch the confirm button to restart the touch switch. At the same time, the Bluetooth name, Bluetooth switch state and voice switch state will all be restored to the factory state.
- Touching the return button will discard the current selection and return to the switch setting menu.

4. Temperature correction setting

- Touch the setting button to enter the switch setting menu.
- Touch the direction key to switch to the temperature correction setting.



- Touch the confirmation button to enter the temperature correction setting interface.

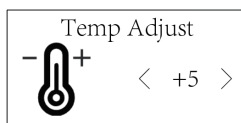

- Touch the direction key to modify the correction temperature (range + 5 °C to - 5 °C).
- Touch the Confirm button to save the corrected temperature.
- Touch the Cancel button to discard the settings and return to the previous interface.

> Fault display

Faults are divided into automatic recovery faults and manual recovery faults after maintenance.



Maintenance: The touch switch is maintenance free.

(You can use a damp cloth or neutral soap solution to clean the panel)

- Automatic recovery fault is a warning fault, which means that an operating parameter has exceeded the defined normal working range and reached an undefined state. In this case, the relevant equipment will continue to operate, and the warning symbol will disappear automatically after the fault is repaired.

(See the fault code table for details)

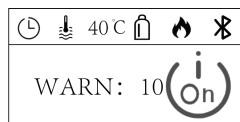

- After the failure of manual recovery occurs, the machine will stop heating. At this time, the water heater should be turned off, and after the failure is found out and solved, choose to reheat.



> Technical parameters

*Display screen:

OLED with backlight, black and white.

*Overall dimension:

87mm × 87 mm× 37.5mm

*Working temperature: - 40 °C ~ +40 °C

*Power supply: DC10.5V ~ 16V

*Power consumption:

standard current: 20 ~ 25mA

standby current: 7 ~ 10mA

Reserves the right to make technical changes

> Installation and operation instructions

The touch switch installed in the vehicle must comply with the corresponding technical and administrative regulations.

1.Safety information:

- Installation and service must be performed by authorized installation personnel and service agents. The warranty will be cancelled in case of property damage, personal injury or loss of life caused by improper installation, change, repair or maintenance.
- Do not use a high-voltage device unless the electronic circuit (circuit board) is disconnected.
- Do not use a battery charger to power the water heater, even during testing.
- If the vehicle requires welding, do not connect the 12 volt DC power supply to the equipment. Electric welding will cause serious damage to the equipment.
- Do not shorten the electrical connection cable. When installing the touch switch, it is necessary to turn off the vehicle's on-board power supply.
- Install the touch switch in a waterproof and damp proof position.

2.Installation location:

- The installation position of the touch switch is convenient for reading and operation.
- Refer to "Figure 17" for the installation opening of the touch switch.

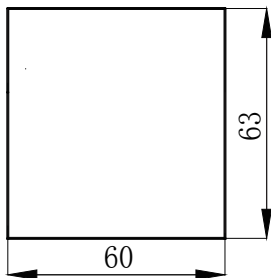

Figure 17

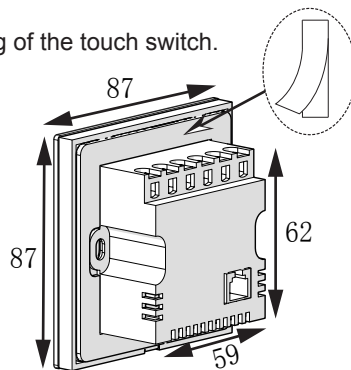

Figure 18

3. Fixed installation:

Dimensions in mm. Not shown to scale.

- The installation opening and fixed surface shall be cleaned, and the fixed surface shall be flat, clean and free of dust and water mist.
- Tear off the release paper of the double-sided adhesive tape on the rear cover of the touch switch, as shown in Figure 18.
- Then place the touch switch in the hole as shown in "Figure 17", and slowly press the screen board until the double-sided adhesive tape is firmly bonded with the fixed surface.



Do not apply any tensile stress to the cable connecting the touch switch.



Never pull the connecting cable connecting the touch screen when the water heater is working. Once the plugs at both ends of the cable fall off from the touch switch or controller, the heating of the water heater will be interrupted, causing failures.

